



**MANUAL**  
**HTC 270 EG**

Translation of manual in original language





HTC 270 EG

## Contact Information

HTC Sweden AB  
Box 69  
SE-614 22 Söderköping - Sweden  
Tel: +46 (0) 121-294 00  
Fax: +46 (0) 121-152 12

You can find addresses for our retailers and service partners on our website:

[www.htc-floorsystems.com](http://www.htc-floorsystems.com)

Always specify the model and serial number when asking questions about your product.

## Trademarks

HTC is a trademark owned by HTC Sweden AB. Other names and products mentioned in this manual may be registered trademarks owned by the relevant companies.

© 2011 HTC Sweden AB. All rights reserved.

# EC Declaration of conformity

Manufacturer:	HTC Sweden AB Box 69 SE-614 22 Söderköping Sweden +46 (0)121-29400
Type of equipment:	Grinding machine
Make:	HTC
Model:	HTC 270 EG
Year of manufacture:	See machine name plate
Serial number:	See machine name plate

As the manufacturer, we hereby declare under our sole responsibility that the above product with serial numbers from 2011 onward conforms to the applicable regulations in directives MD 2006/42/EC, EMC 2004/108/EC and LVD 2006/95/EC. The following standards have been used as a basis: ISO 5349-1:2001, ISO 5349-2:2001, ISO 20643:2005, ISO 3741.

This product was CE-marked in 2011. The technical documentation is available from the manufacturer.

Original of the EC declaration of conformity (Swedish). Other languages are translations of the original of the EC declaration of conformity.

Söderköping 06/04/2011



Peter Lundgren  
Development Manager,  
HTC Sweden AB



Kåre Kilgren  
Product Manager,  
HTC Sweden AB

<b>1</b>	<b>Introduction</b>	<b>1</b>
1.1	General Information .....	1
1.2	Responsibility .....	1
1.3	Manual .....	1
1.3.1	Safety Instructions – Explanation of Symbols ....	1
1.4	Transportation .....	2
1.5	On delivery .....	2
1.6	Unpacking the machine .....	3
1.7	Machine name plate .....	3
1.8	Handling and storage .....	4
1.9	Vibration and noise .....	4
1.9.1	Hand and arm vibrations .....	4
1.9.2	Sound power level .....	4
<b>2</b>	<b>Safety</b>	<b>5</b>
2.1	General Information .....	5
2.2	Warnings .....	5
2.3	Notes .....	6
<b>3</b>	<b>Machine description</b>	<b>9</b>
3.1	General machine description .....	9
3.2	Description of controls – Control panel .....	11
3.3	Lifting the machine .....	12

<b>4</b>	<b>Usage</b>	<b>13</b>
4.1	General Information .....	13
4.2	Handle settings .....	14
4.3	Access to grinding tools .....	15
4.4	Fitting and replacing grinding tools .....	16
4.4.1	Fitting grinding tools .....	17
4.4.2	Changing grinding tools .....	19
4.5	Fitting extra weights .....	19
4.6	Preparations for dry grinding .....	21
4.7	Preparations for wet grinding .....	21
4.8	Operation .....	22
4.8.1	Standby .....	22
4.8.2	Emergency stop switch .....	23
4.8.3	Starting the machine .....	23
4.8.4	Overload .....	23
4.9	Adjustment of grinding head .....	24
4.9.1	Adjustment of grinding head against walls .....	24
4.9.2	Setting the grinding head position .....	24
4.9.3	Adjusting the machine before and during grinding .....	26
4.10	Transportation .....	29
<b>5</b>	<b>Maintenance and repairs</b>	<b>30</b>
5.1	General Information .....	30
5.2	Cleaning .....	30
5.3	Daily .....	30
5.4	Every week .....	30
5.4.1	Check and cleaning of belt .....	31
5.5	Every month (or 100 hours) .....	32
5.6	Repairs .....	33
5.7	Spare parts .....	33
<b>6</b>	<b>Faultfinding</b>	<b>34</b>
6.1	General Information .....	34
6.2	The machine will not start .....	34
6.3	The machine vibrates or wears the tool unevenly .....	34
6.4	The machine is grinding at an angle .....	34
6.5	The machine stops immediately after starting .....	35
6.6	The fuses trip frequently .....	35
6.7	The machine cannot cope .....	35

---

<b>7</b>	<b>Electronic error codes</b>	<b>36</b>
7.1	General Information .....	36
7.2	Schneider Electric ATV12 .....	36
7.2.1	Resetting the frequency converter .....	36
7.2.2	Checking the last error code .....	37
7.3	Schneider Electric ATV312 .....	37
7.3.1	Resetting the frequency converter .....	38
7.3.2	Checking the last error code .....	38
<b>8</b>	<b>Technical data</b>	<b>40</b>
<b>9</b>	<b>Environment</b>	<b>44</b>
<b>10</b>	<b>Warranty and CE marking</b>	<b>45</b>
10.1	Warranty .....	45
10.2	CE marking .....	45





# 1 Introduction

## 1.1 General Information

HTC 270 EG is a grinder that can be used to grind, strip, clean and polish concrete, unhewn stone and terrazzo as well as wood floors. The machine's area of application depends on the choice of tool.

Read the manual carefully, so you are totally familiar with the machine before you start to use it. Contact your local retailer for further information. For contact information, see Contact Information at the start of the manual.

## 1.2 Responsibility

Even though every effort has been made to make this manual as complete and accurate as possible, we bear no responsibility for incorrect or missing information. HTC reserves the right to change descriptions in this manual without giving prior notice.

This manual is protected by the Copyright Act and no part of it may be copied or used in any other way without the written approval of HTC.

## 1.3 Manual

In addition to the general functions, this manual deals with the areas of application and the maintenance of the grinder.

### 1.3.1 Safety Instructions – Explanation of Symbols

A number of symbols are used in the manual to highlight the most important sections, see below. In order to avoid both personal injury and material damage as far as possible, it is extremely important to read and understand the text next to these symbols particularly carefully. There are other symbols indicating practical tips. These are to help you use the machine in the easiest and most effective way.

The following symbols are used in the document to indicate where special attention is needed.



#### **Warning!**

This symbol means **Warning!** and indicates that incorrect use can result in material damage to the machine or accessories. If you see this symbol next to a section of text, you must be particularly careful when reading through the text and not carry out any stages of which you are unsure. This is for your own and other users' safety and to avoid damage to machinery or other equipment.

**Note!**

This symbol means **Note!** and indicates that material damage can occur if the machine or its accessories are used incorrectly. If you see this symbol next to a section of text, you must be particularly careful when reading through the text and not carry out any stages of which you are unsure. This is to avoid damage to the machine or other equipment.

**Tip!**

This symbol means **Tip!** and indicates that you can get tips and advice on ways to make operating your machine or associated equipment easier, and to avoid wear. If you see this symbol next to a text, you should read through the text to make your work easier and to extend the service life of the machine.

## 1.4 Transportation

Always make sure that the grinder is securely anchored to its surroundings and the grinding head is lowered against the surface. To prevent the machine from being damaged while it is secured, make sure that a spacing block is placed as support, see Transportation, page 29. Make sure that the securing straps or other equipment used for anchoring during transport are tightened over non-moving parts, e.g. the grinder's chassis.

When lifting the grinder, lifting straps must be used. These must be attached well-secured in the lifting eyes provided, , position 2, Figure 3-1, page 9. Only use lifting straps approved for lifting equipment.

Do not transport the grinder on sloping surfaces, e.g. loading ramps, without securing it by the lifting eyes, , position 2, Figure 3-1, page 9 for example with a winch. This is a safety measure in case the grinder starts to roll out of control. Also make sure that people (including operator) in the vicinity are at a safe distance in order to prevent personal injury, in the event that the grinder starts to roll out of control.

## 1.5 On delivery

The following items are included in the delivery. Contact your retailer if anything is missing.

- Grinding machine
- Manual disc
- Locking key for control cabinet
- Hammer EZ system

- Gloves
- HTC Cap

## 1.6 Unpacking the machine



### Warning!

Read through the safety instructions and the manual carefully before use.

- Check carefully to see if the packaging or machine has been damaged during delivery. If there is any sign of damage, contact your retailer and report it. Report packaging damage to the transport company as well.
- Check that the delivery matches the order. If there are any discrepancies, contact your retailer.
- When lifting the grinder, lifting straps must be used. These must be attached well-secured in the lifting eyes provided, , position 2, Figure 3-1, page 9. Only use lifting straps approved for lifting equipment.

## 1.7 Machine name plate

The machine name plate provides the following information. The model and serial number must be specified when ordering spare parts for the machine.

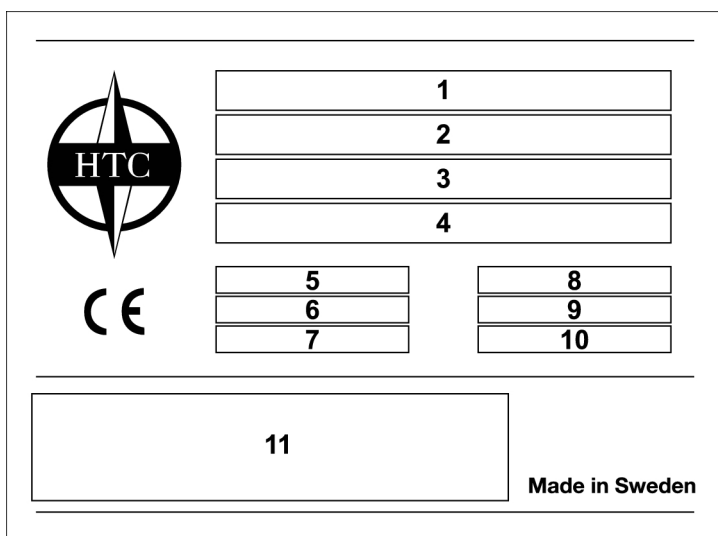

Figure 1-1. Machine name plate

1. Model
2. Model number
3. Serial number
4. Year of manufacture
5. Power (kW)

6. Voltage (V)
7. Current (A)
8. Frequency (Hz)
9. Rotational speed (r.p.m.)
10. Weight (kg)
11. Address field

## 1.8 Handling and storage

The machine should be stored in a heated, dry area when not in use. Otherwise, it may be damaged by condensation and cold.

When lifting the grinder, lifting straps must be used. These must be attached well-secured in the lifting eyes provided, , position 2, Figure 3-1, page 9. Only use lifting straps approved for lifting equipment.

## 1.9 Vibration and noise



### Warning!

Always use hearing protection when using the machine.

### 1.9.1 Hand and arm vibrations

Hand and arm-weighted vibration level [ $\text{m/s}^2$ ] for HTC 270 EG have been measured using equipment approved in accordance with ISO 5349-1:2001. Measurement uncertainty for the measuring equipment is given as +/- 2%.

The machine has been tested in accordance with ISO 5349-2:2001 and ISO 20643:2005 in order to identify the operations that contribute to the most frequent vibration exposures. At vibration levels  $> 2.5 \text{ m/s}^2$ , the exposure time should be limited in accordance with the table below. For vibration levels  $> 5 \text{ m/s}^2$ , immediate measures must be taken by the employer to ensure that the exposure time does not exceed the time specified in the table below.

Identified work conditions	Measured values [ $\text{m/s}^2$ ]	Daily permitted exposure (number of hours)
Grinding/polishing	3.92	13
Floor preparation (T-rex)	3.75	14.2

### 1.9.2 Sound power level

This machine is tested for noise in accordance with ISO 3741 . For information on the sound power level, see the table in chapter Technical data, page 40.

## 2 Safety

### 2.1 General Information

This chapter contains all of the warnings and observations that should be taken into consideration for HTC 270 EG.

### 2.2 Warnings

**Warning!**

The machine may only be used or repaired by personnel who have received the appropriate theoretical and practical training and who have read this manual.

**Warning!**

Never use the machine in an environment where there is a risk of explosion or fire. Familiarise yourself with the fire-protection instructions for the working area and follow them.

**Warning!**

Secure the area around the machine. No unauthorised persons should be within a 15-metre radius of the machine. If loose objects get under the grinding head, these may be flung out and cause personal injury.

**Warning!**

Use safety equipment such as safety shoes, safety glasses, protective gloves, a mask and hearing protection.

**Warning!**

Always make sure that a dust extractor is connected to the grinder during dry grinding to prevent exposing as far as possible operators, people in the vicinity, the grinder and other equipment to dust particles. Exposure to dust particles can cause personal injury and also damage to physical equipment.

**Warning!**

Only start the machine with the grinding head lowered. The rotating disc must be touching the floor and the right tool must be fitted.

**Warning!**

Read through the safety instructions and the manual carefully before use.

**Warning!**

Always use hearing protection when using the machine.

**Warning!**

During grinding, the tools become very hot. Tip the machine back and allow it to stand for a short while. Use protective gloves when removing the tools.

**Warning!**

Disconnect the electrical supply when cleaning, changing tools or repairing the machine.

**Warning!**

The machine may only be used and moved on horizontal surfaces. There is a risk of crush injuries if the machine starts to roll.

**Warning!**

The machine must be connected to a residual current device.

**Warning!**

Do not clean the machine using a high-pressure washer. Otherwise, moisture may penetrate electrical elements and damage the machine's drive system.

**Warning!**

The grinding head must not be loaded with any other weights in addition to the intended extra weights. Do not under any circumstances stand on the grinding head. Too high a loading can cause the grinding head to fail.

**Warning!**

When using tools with few points of contact with the surface, e.g. single segment tools, there is a risk that the ground surface will not be even. For this reason, such tools should be used with care and only when a roughly ground surface will not spoil the finished result after grinding.











**Warning!**

When working on an elevated surface where there is a risk of falling, the edges of the surface must be secured. The values for the machine's thrust and load capacity as well as the driving speed are given in the table for the machine's technical data in the chapter "Technical Data".

## 2.3 Notes

**Note!**

The machine may only be used to grind and polish natural stone, terrazzo, concrete, wood, or other materials stated in this manual or that are approved by HTC.

-  **Note!**  
Only original tools and spare parts from HTC may be used for the machine. Otherwise, neither the CE marking nor the warranty will be valid.
-  **Note!**  
For the CE marking to be valid, the instructions in this manual must be followed.
-  **Note!**  
The machine must only be lifted using the lifting eye intended (position 2 in Figure 3-1, page 9) for the purpose in accordance with the relevant instructions.
-  **Note!**  
The machine should be stored in a dry, warm (plus degrees) location when not in use.
-  **Note!**  
If the machine is stored in a cold area (below zero), it must be kept in a warm area (above zero) for at least two hours before use.
-  **Note!**  
When dry grinding, a suitable dust extractor should be used. For available models of dust extractors, go to HTC's website [www.htc-floorsystems.com](http://www.htc-floorsystems.com) for more information.
-  **Note!**  
The dust extractor's suction hose must be connected to the appropriate socket on the machine. Adjust the dust extractor to match the grinder's capacity.
-  **Note!**  
Do not use the emergency stop switch to stop the machine, except in emergencies.
-  **Note!**  
As long as the emergency stop switch is pressed in, the machine cannot be started. Reset by turning the switch 45° clockwise so that it pops out again. The machine can then be restarted.
-  **Note!**  
After removing glue and wet grinding, always lift up the grinding heads so that they do not stick to the floor and damage machine components and the floor when restarting.

**Note!**

Only use cold water with no chemical additives.

**Note!**

During transport, the machine must be secured for transport according to section Transportation, page [29](#). Always place a spacing block under the grinding head during transport to prevent the machine cracking.



### 3 Machine description

#### 3.1 General machine description

The machine is a grinder for floors, and it is specially adapted for grinding the floor surface bordering on walls or other permanently installed equipment. The machine is constructed with a grinding head that is suitable for grinding under radiators, shelves or other projecting furnishings. The machine has adjustment options and functions for easily obtaining the best possible grinding result.

The machine can be easily equipped with a large number of tools, depending on the floor material to be ground. For other tools, go to HTC's website [www.htc-floorsystems.com](http://www.htc-floorsystems.com) for more information.

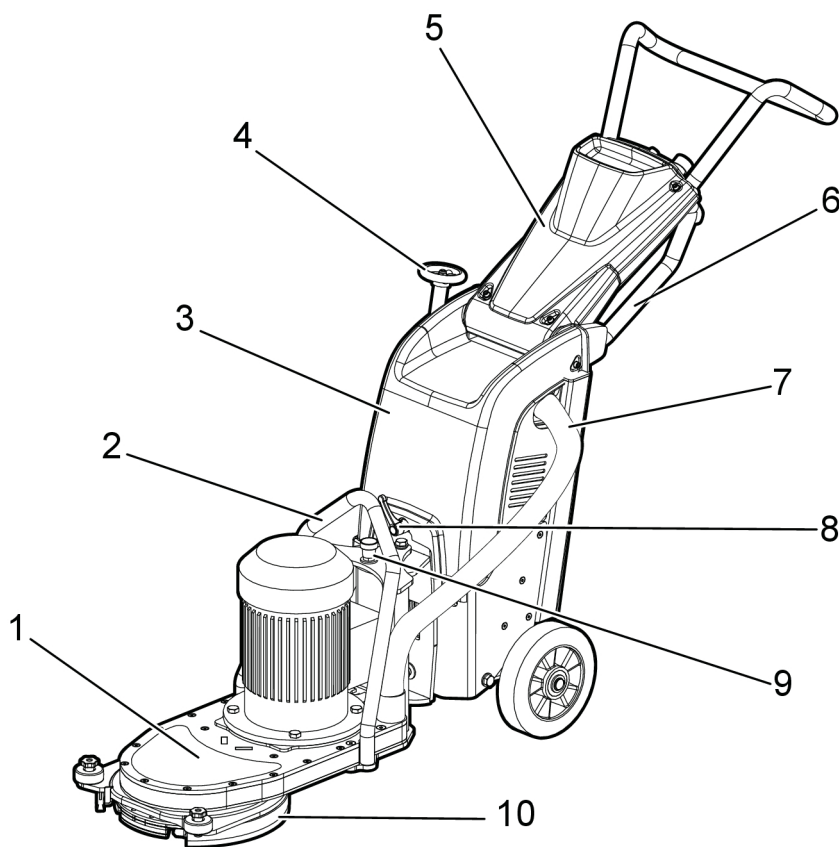

G000503

Figure 3-1. The front of the machine

- 1. Grinding head
- 2. Lifting eye
- 3. Chassis
- 4. Knob for adjusting grinding head
- 5. Adjustable handle
- 6. Handle for forward working position

7. Suction hose
8. Lever for adjusting grinding head
9. Locking pin position grinding head
10. Rotatable floating grinding cover

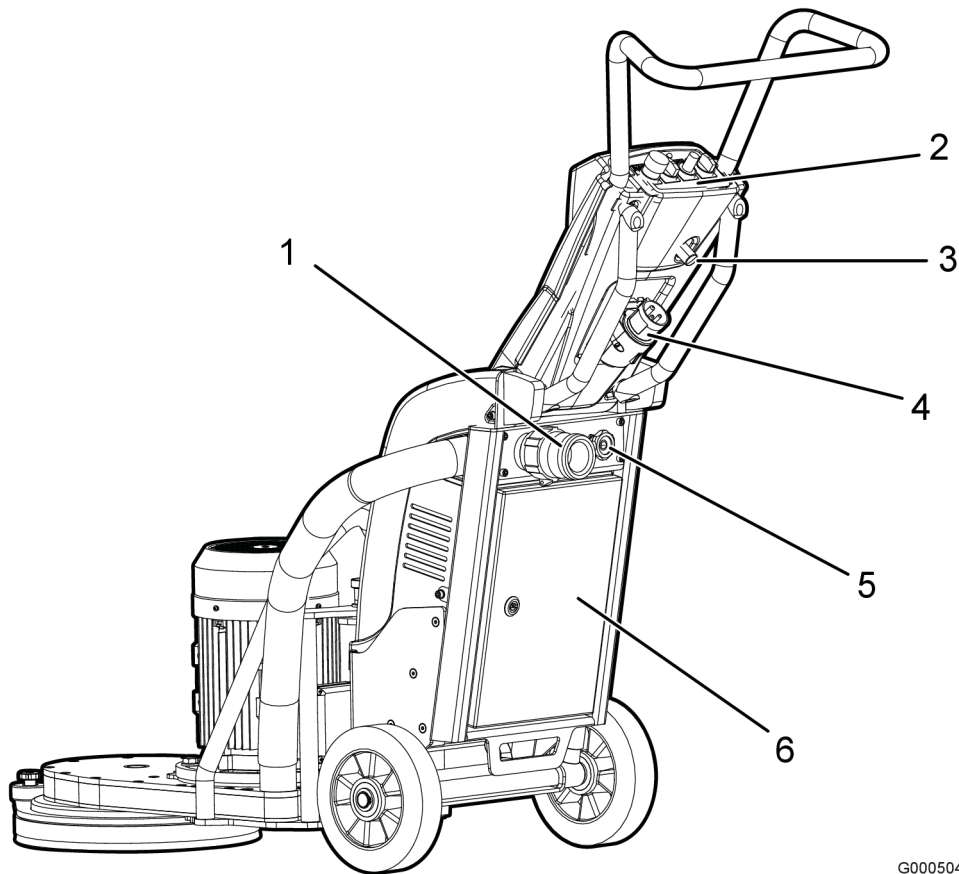

G000504

Figure 3-2. The machine's rear

1. Connection for vacuum
2. Control panel
3. Locking handle position
4. Electrical connection
5. Water connection
6. Control cabinet

### 3.2 Description of controls – Control panel

The picture below shows the machine's control panel:

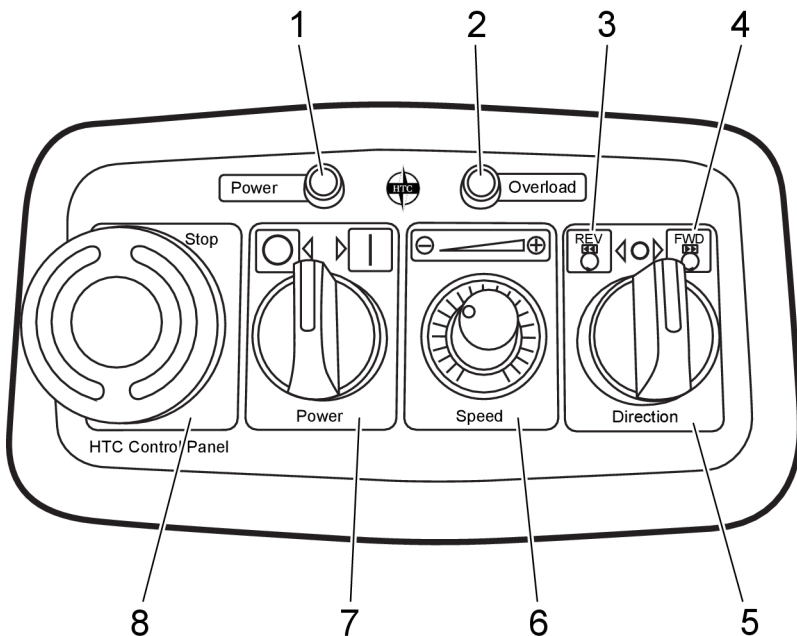
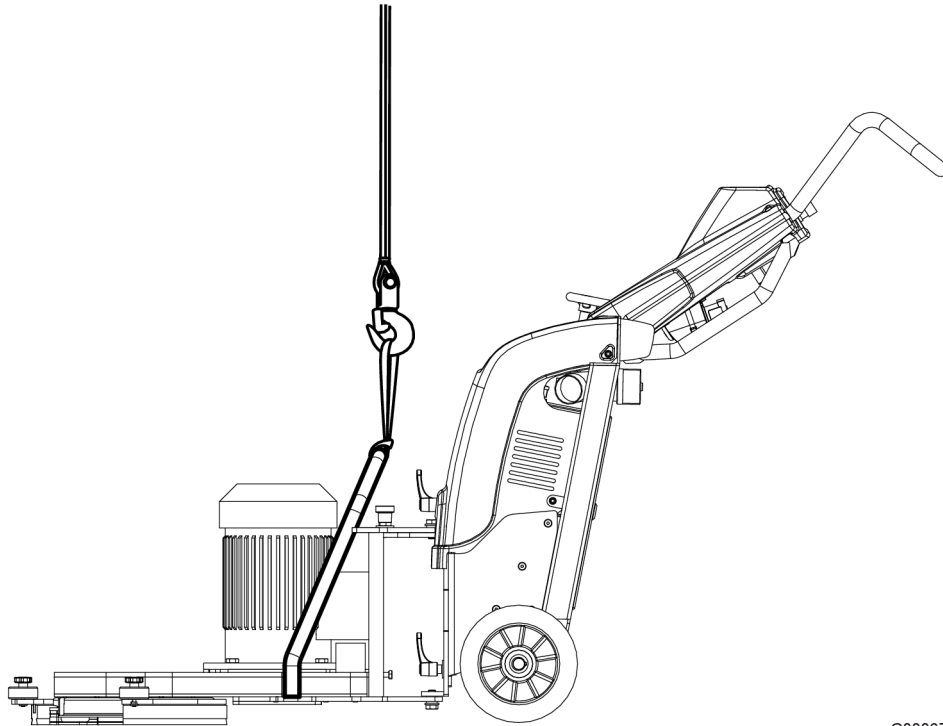

Figure 3-3. Control panel

1. **Power** - Standby indicator: Indicates that the machine's functions have been activated. Lights up when the Power knob (7) is turned to "I".
2. **Overload** - Overload indicator: Lights up to indicate that the machine is using too much power. If this is ignored, the power supply to the motor will be interrupted and an error code generated.
3. **REW** - Rewind: Turn the Grinding knob (5), to "REW" to start the machine's grinding disc.
4. **FWD**- Forward: Turn the Grinding knob (5), to "FWD" to start the machine's grinding disc.
5. **Grinding** - "Reset" (3) and "FWD" (4) knob.
6. **Speed** - Rotation speed: Regulates the rotational speed of the machine's grinding disc.
7. **Power** - Start/stop the machine's functions: Turn the knob to "I" to activate the machine's functions and to prepare for start. Turn the knob to "O" to switch off the machine's functions.
8. **EM-Stop** - Emergency stop switch: In an emergency, press the switch to cut the power to the machine.

### 3.3 Lifting the machine

When lifting the machine, lifting straps are used that fasten in the lifting eyes on the chassis, see Figure 3-4, page 12. Only use straps approved for lifting equipment.



G000675

*Figure 3-4. Lifting the machine*

## 4 Usage

### 4.1 General Information

The following section describes how to change tools and how to operate the grinding machine. This section does not deal with the technical aspects of grinding, such as selection of grinding tools, etc. For choice of tool, go to HTC's website [www.htc-floorsystems.com](http://www.htc-floorsystems.com) for more information.

**Warning!**

The machine may only be used or repaired by personnel who have received the appropriate theoretical and practical training and who have read this manual.

**Warning!**

Never use the machine in an environment where there is a risk of explosion or fire. Familiarise yourself with the fire-protection instructions for the working area and follow them.

**Warning!**

Secure the area around the machine. No unauthorised persons should be within a 15-metre radius of the machine. If loose objects get under the grinding head, these may be flung out and cause personal injury.

**Warning!**

Use safety equipment such as safety shoes, safety glasses, protective gloves, a mask and hearing protection.

**Warning!**

Only start the machine with the grinding head lowered. The rotating disc must be touching the floor and the right tool must be fitted.

**Warning!**

The machine must only be used and moved on level surfaces. There is a risk of crush injuries if the machine starts to roll.

**Warning!**

The grinding head must not be loaded with any other weights in addition to the intended extra weights. Do not under any circumstances stand on the grinding head. Too high a loading can cause the grinding head to fail.

**Tip!**

Check the minimum recommended cable area before using an extension cord. You will find the recommended cable area under Technical data, page 40.

## 4.2 Handle settings

The picture below shows the handle positions on the machine.

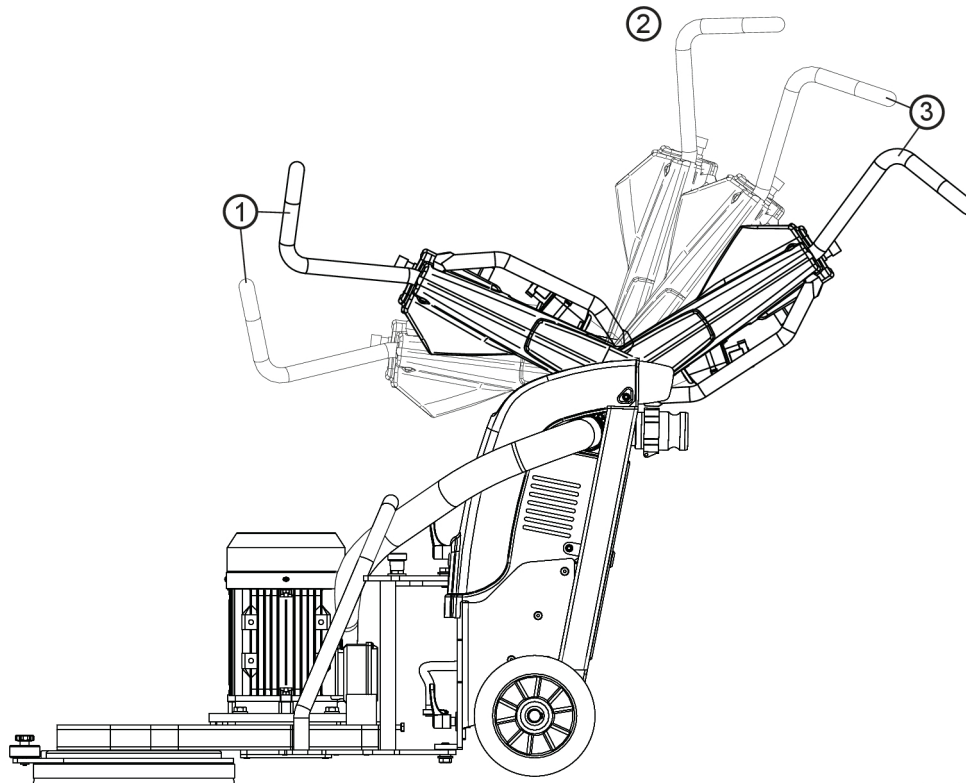

G000505

Figure 4-1. Handle settings

1. Forward position - used during transport, since the machine then takes significantly less room, and as the working position for handling the machine during grinding where a better view and precision are required.
  2. Vertical position - used for tipping the machine, to make changing the tools easier.
  3. Rear position - the working height can be adjusted to one of two positions using the machine's adjustable handle.
- Lock the handle in the required position using the locking mechanism located on the underneath of the handle cover, see position 3 in Figure 3-2, page [10](#).

To obtain a good grip and the possibility to control the grinder properly during grinding with the handle in any of the forward positions, use grip 1 and 2 according to Figure 4-2, page 15.

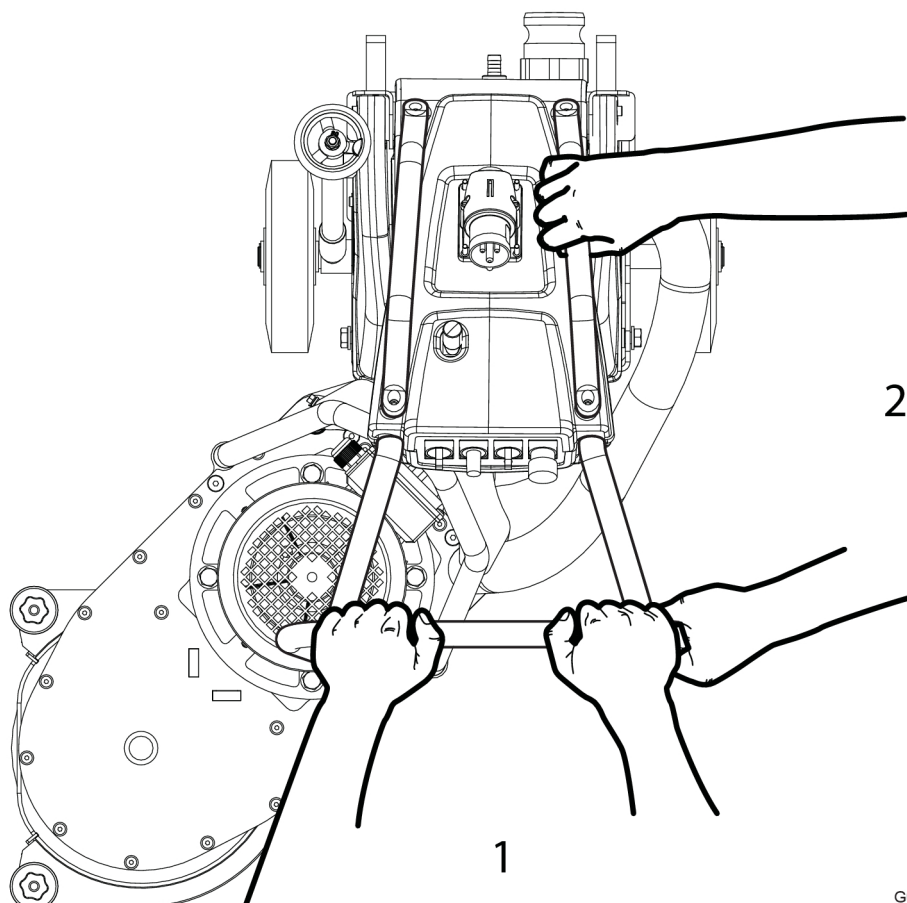

G000506

Figure 4-2. Handholds forward position

### 4.3 Access to grinding tools



**Warning!**

During grinding, the tools become very hot. Tip the machine back and allow it to stand for a short while. Use protective gloves when removing the tools.



**Warning!**

Disconnect the electrical supply, when changing tools or repairing the machine.



**Warning!**

Make sure that extra weights are removed before tipping the machine. The weights can come loose and cause damage and injuries.

1. Set the handle to the upright position - see Handle settings, page [14](#)
2. Tip the machine backwards, so it rests on the ground.

## 4.4 Fitting and replacing grinding tools



**Warning!**

Disconnect the electrical supply, when changing tools or repairing the machine.



**Warning!**

During grinding, the tools become very hot. Tip the machine back and allow it to stand for a short while. Use protective gloves when removing the tools.



**Warning!**

When using tools with few points of contact with the surface, e.g. single segment tools, there is a risk that the ground surface will not be even. For this reason, such tools should be used with care and only when a roughly ground surface will not spoil the finished result after grinding.



#### **4.4.1 Fitting grinding tools**

1. Slide the grinding tool diagonally from above down into the appropriate guide slot on the tool holder. Then push the tool fully into the guide slot, see Figure 4-3, page 18.

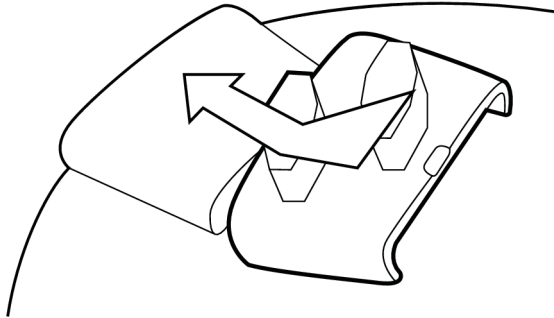

G000496

Figure 4-3. Fitting grinding tools

2. Lock the grinding tool into the tool holder by giving it a few light taps with a rubber hammer - see Figure 4-4, page 18.



G000497

Figure 4-4. Locking grinding tools

#### 4.4.2 Changing grinding tools

1. Remove the grinding tool by giving it a few light taps with a rubber hammer so the locking mechanism releases, see Figure 4-5, page 19. Then draw the tool up out of the guide slot.

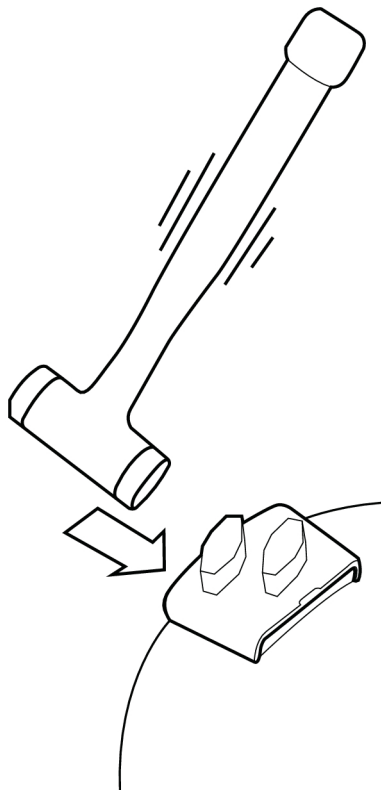

G000499

Figure 4-5. Removing grinding tools

2. Slide the grinding tool diagonally, from above, down into the appropriate guide slot on the tool holder, see Figure 4-3, page 18. Then push the tool fully into the guide slot.
3. Lock the grinding tool into the tool holder by giving it a few light taps with a rubber hammer - see Figure 4-4, page 18.

#### 4.5 Fitting extra weights



**Warning!**

Make sure that extra weights are removed before tipping the machine. The weights can come loose and cause damage and injuries.

The extra weights are used to increase the grinding pressure but they should only be used when it is absolutely necessary. Do not add on more weight than needed. The weights lie loose and rest on the ring fitted to the motor.

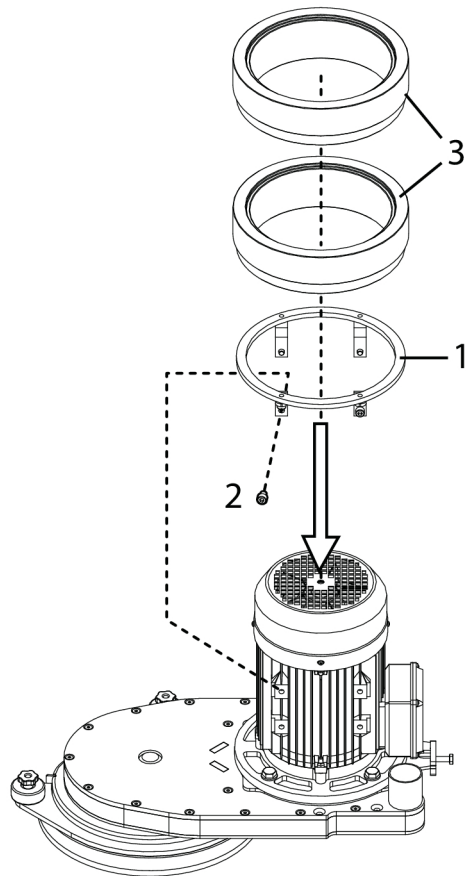

G000676

Figure 4-6. Fitting extra weights

1. Attach the enclosed ring, position 1, Figure 4-6, page 20, by threading it over the motor.
2. Screw the ring securely into place using the enclosed screws, position 2, Figure 4-6, page 20. The ring must be secured in the upper holes on the motor.
3. Add one or two weights depending on the grinding pressure required, position 3, Figure 4-6, page 20. Do not add more weight than necessary.

## 4.6 Preparations for dry grinding

1. Connect a dust extractor to the machine. For available models of dust extractors, go to HTC's website [www.htc-floorsystems.com](http://www.htc-floorsystems.com) for more information.

**Note!**

The dust extractor's suction hose must be connected to the appropriate socket on the machine. Adjust the dust extractor to match the grinder's capacity.

2. Inspect the floor carefully and remove any objects sticking up, such as reinforcement rods or bolts, and any debris that could get caught in the machine.
3. Attach the appropriate tool to the machine.
4. Set the handle to the required working position.

**Warning!**

The grinding head must not be loaded with any other weights in addition to the intended extra weights. Do not under any circumstances stand on the grinding head. Too high a loading can cause the grinding head to fail.

## 4.7 Preparations for wet grinding

1. Always use liquid suction when wet grinding.

**Tip!**

Never use a dust extractor, as it may cause blockages in the dust extractor's suction hose.

2. Inspect the floor carefully and remove any objects sticking up, such as reinforcement rods or bolts, and any debris that could get caught in the machine.
3. Attach the appropriate tool to the machine.
4. Set the handle to the required working position.

**Warning!**

Only use cold water with no chemical additives.

5. Connect a water hose to the intended connection and turn on the desired water flow, see Figure 4-7, page 22.

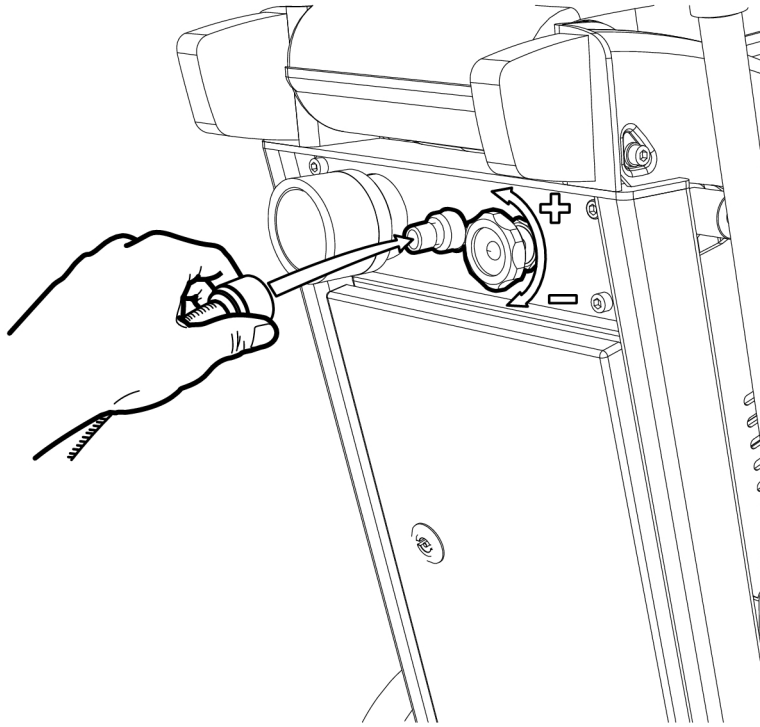

G000507

Figure 4-7. Connecting water



### **Warning!**

The grinding head must not be loaded with any other weights in addition to the intended extra weights. Do not under any circumstances stand on the grinding head. Too high a loading can cause the grinding head to fail.

## **4.8 Operation**

The machine's functions can be controlled using the control panel - see section Description of controls – Control panel, page 11.

During operation, the operator pushes the grinder forwards over the floor surface.

### **4.8.1 Standby**

To activate the machine's functions, turn the Power knob to "I". Once the knob set to this position, the Power indicator on the control panel lights up, indicating that the machine is in standby mode.

### 4.8.2 Emergency stop switch

The emergency stop switch, (EM-Stop) must only be used in an emergency.

When the switch is pressed, all electrically-powered equipment on the machine are turned off.



**Note!**

Do not use the emergency stop switch to stop the machine other than in emergencies, as it can damage the machine.



**Note!**

As long as the emergency stop switch (EM-Stop) is pressed, the machine cannot be started. Reset by turning the switch 45° so that it pops out again. The machine can then be restarted.

### 4.8.3 Starting the machine

For a description of the control panel, see section Description of controls – Control panel, page [11](#).

1. Connect the electricity supply by plugging in the plug.
2. Make sure the emergency stop switch is reset.
3. Turn the Power knob to "I" to activate the electronics.
4. Set the speed for the grinding discs using the Speed knob.
5. Turn the Grinding knob to "FWD".
6. The machine has now started.

### 4.8.4 Overload

If the machine is using too much power, the Overload indicator on the control panel goes off. The machine switches off automatically after a while if this is ignored. Reduce the speed of the grinding discs to see if the Overload indicator goes out. If this does not help, follow the procedure for troubleshooting, see chapter Faultfinding, page [34](#).

## 4.9 Adjustment of grinding head

### 4.9.1 Adjustment of grinding head against walls

Set the grinding tool's minimum working distance to the wall, with the help of the two small support wheels. You move the respective wheel inwards or outwards to the desired position by turning the knob on top of the wheel, see Figure 4-8, page 24. Check the distance to the wall before you start grinding, so there is no risk that the grinding disc or tool will collide with the wall.

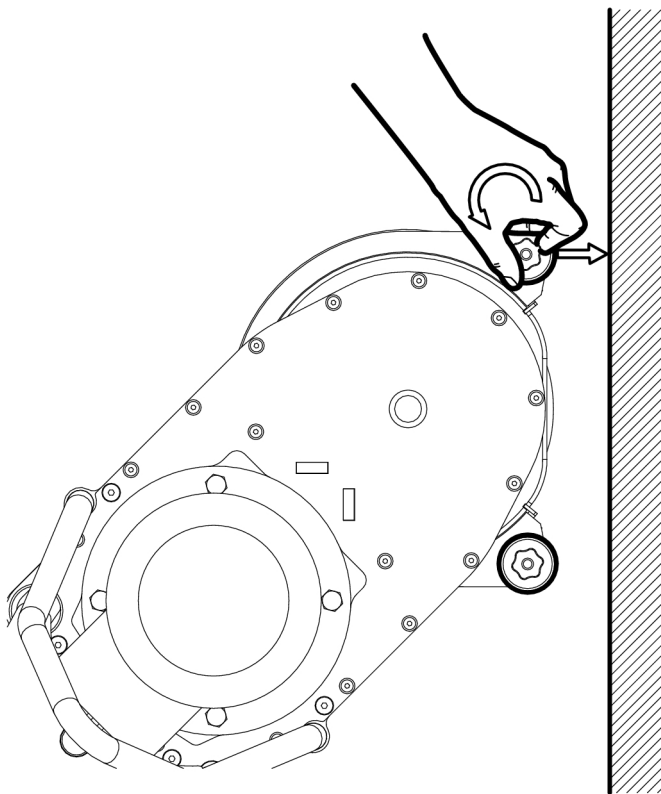

G000508

Figure 4-8. Adjustment of grinding head against walls

### 4.9.2 Setting the grinding head position

The grinding head can be placed in three positions for grinding, to the right (45°), to the left (45°) or straight forwards. You choose the position for the grinding head as follows:



1. Pull up the locking pin, see Figure 4-9, page 25 and position 9 in Figure 3-1, page 9.

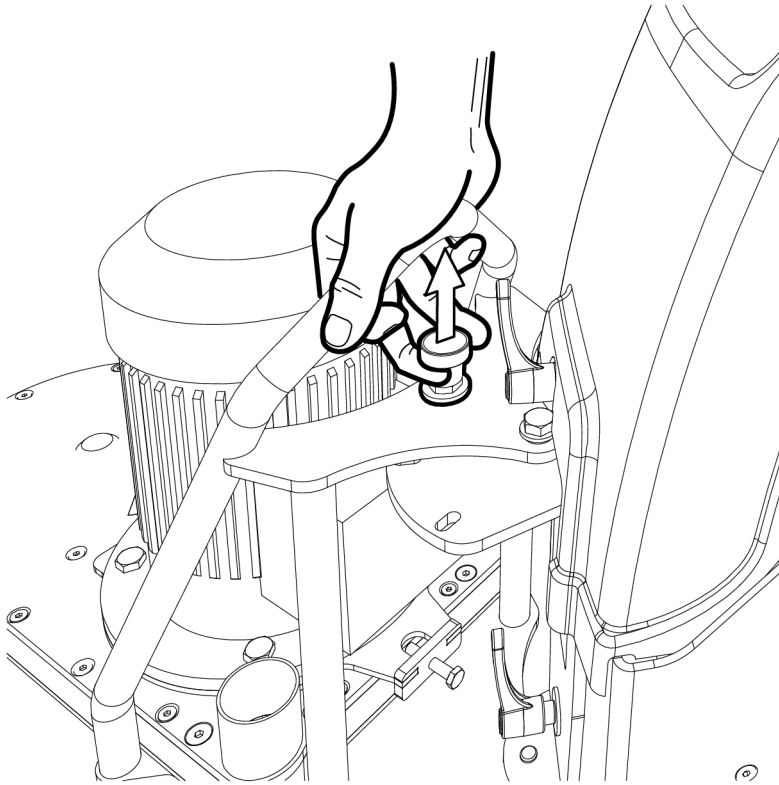

G000509

*Figure 4-9. Loosening locking pin for grinding head*

2. Turn the rear section of the machine to the desired position by pressing or pulling the handle at the same time as you hold the locking pin up, see Figure 4-10, page 26.

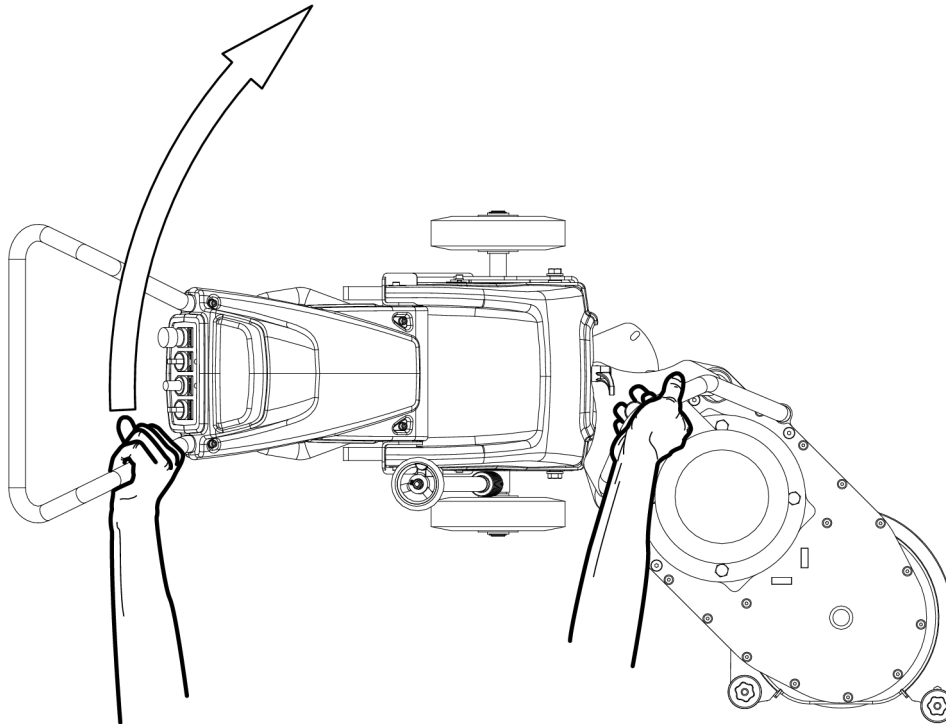

G000510

Figure 4-10. Setting the grinding head position

3. Release the locking pin and make sure it locks the grinding head in the desired position.

### 4.9.3 Adjusting the machine before and during grinding

To obtain a good grinding result, the machine's grinding head has to be adjusted so it is horizontal. This is done as follows:

1. Place the machine on a floor that is level and horizontal.
2. Attach the grinding tool according to section Fitting and replacing grinding tools, page 16.
3. Choose the position for the grinding head, right, left or straight forwards according to section Setting the grinding head position, page 24.

4. Turn the adjustment wheel in Figure 4-11, page 27 until level A (for right position) or level B (for left position) is levelled.

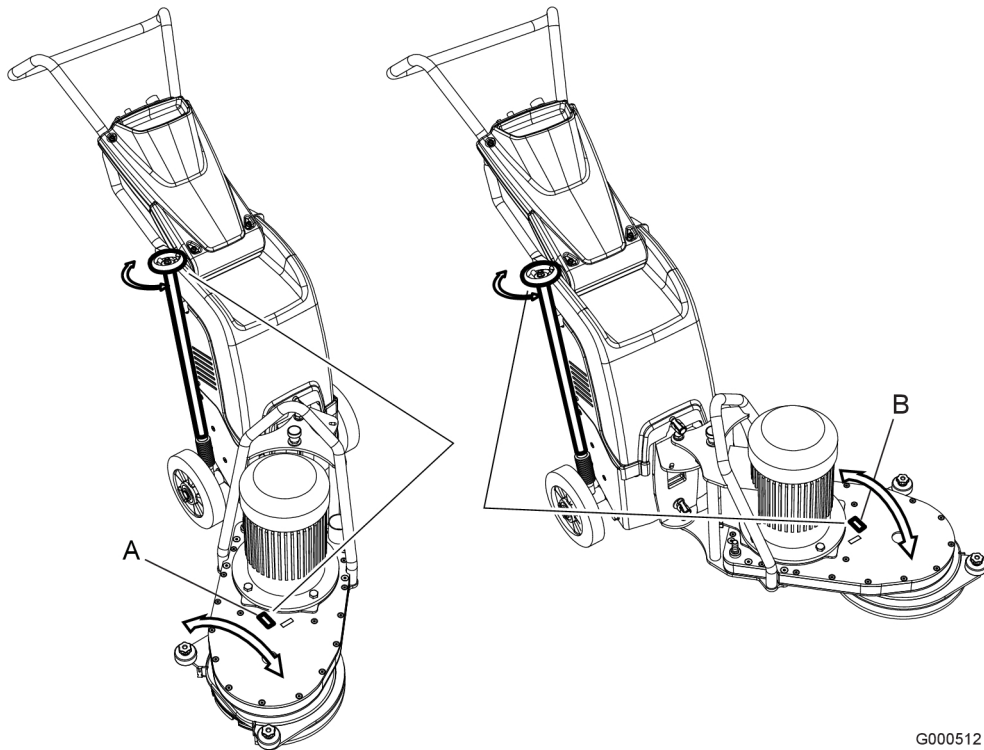
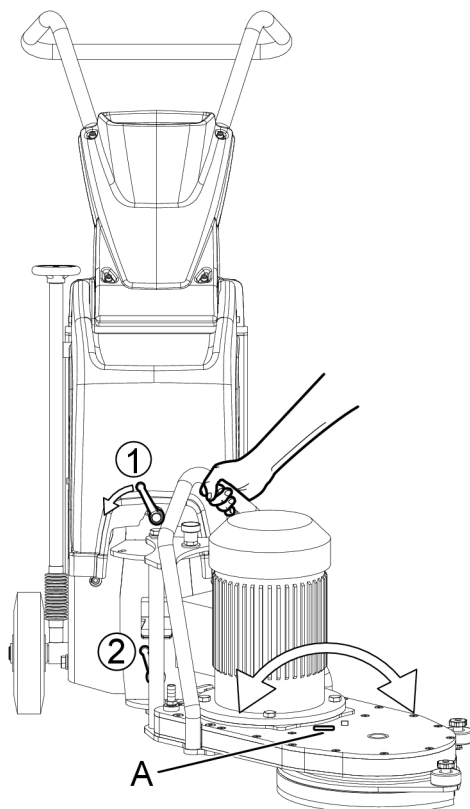

Figure 4-11. Adjustment of grinding head in level 1

- Loosen the levers 1 and 2 in Figure 4-12, page 28 so the grinding head can be turned. Turn the adjustment wheel until level B (for right position) or level A (for left position) is levelled.



G000513

Figure 4-12. Adjustment of grinding head in level 2 (shows the grinding head in left position)

- When the adjustment is completed, first tighten lever 1 and then lever 2 in Figure 4-12, page 28.
- If necessary, readjust more exactly according to point 4 above.



**Tip!**

During grinding, the tools are worn and used up, which affects the grinding head and the tool's angle to the floor. For this reason, to prevent a change in angle that can degrade the result of the grinding, the wear on the tool must be compensated for during the course of the work, by making adjustments using the adjustment wheel in Figure 4-11, page 27.



**Tip!**

After changing to new or other grinding tools, the grinding head must be checked to make sure it is horizontal. Follow steps 3 to 7 in the instruction above to check, and where necessary, make adjustments so the grinding head is horizontal.

**Tip!**

After a change in the grinding head's position (right/left/straight forwards) during grinding (according to section Setting the grinding head position, page 24 above), the grinding head must be checked to make sure it is horizontal. Follow steps 4 to 7 in the instruction above to check, and where necessary, make adjustments so the grinding head is horizontal.

## 4.10 Transportation

During transport, the machine must be secured for transport with one or more crossed straps. To prevent damage to chassis parts, a spacing block must always be placed under the grinding head during transport, see Figure 4-13, page 29.

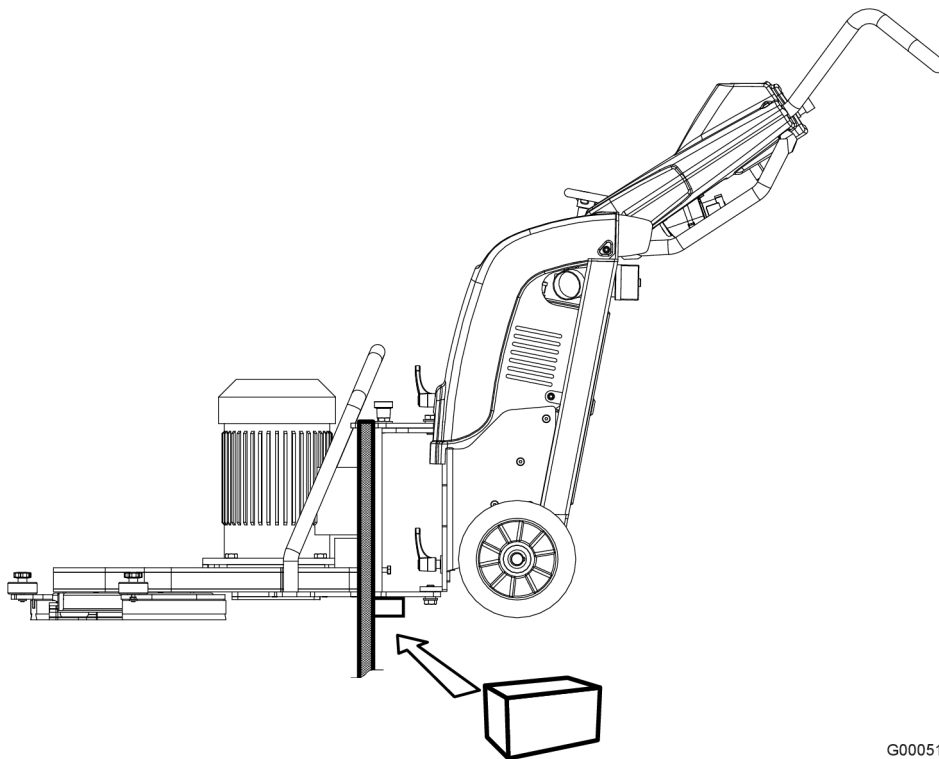

G000511

Figure 4-13. Securing the machine for transport

## 5 Maintenance and repairs

### 5.1 General Information

We recommend regular inspections of all seals.



**Warning!**

Disconnect the electrical supply, when changing tools or repairing the machine.



**Warning!**

Use safety equipment such as safety shoes, safety glasses, protective gloves, a mask and hearing protection.

### 5.2 Cleaning



**Warning!**

Do not clean the machine using a high-pressure washer. Otherwise, moisture may penetrate electrical elements and damage the machine's drive system.

- Vacuum clean the control cabinet, if required.
- Always clean the machine after use with a damp sponge or cloth.

### 5.3 Daily

- Wash the machine if it has been used for wet grinding.
- Check for wear to grinding tools – abnormal or uneven wear may indicate a damaged grinding holder.
- Check the tool holder and grinding holder to ensure that no damage or cracks have arisen. Replace the parts if there is any damage.
- Check that the brush strip on the grinding cover is not damaged and that it is correctly attached.

### 5.4 Every week

- Wash the machine.
- Check the grinding holder. Remove the tools and run the machine in mid air at the slowest speed. If the grinding holder oscillates or wobbles significantly, it is damaged.
- Check and clean the filter in the control cabinet.

- Check and clean the belt, see section Check and cleaning of belt, page [31](#).

### 5.4.1 Check and cleaning of belt

1. Place the handle in the upright position and tip the machine back, in the same way as when changing tools, see [Access to grinding tools](#), page [15](#).
2. Unscrew the inspection cover on the underneath of the grinding head so the belt is visible and can be checked, see [Figure 5-1](#), page [31](#).

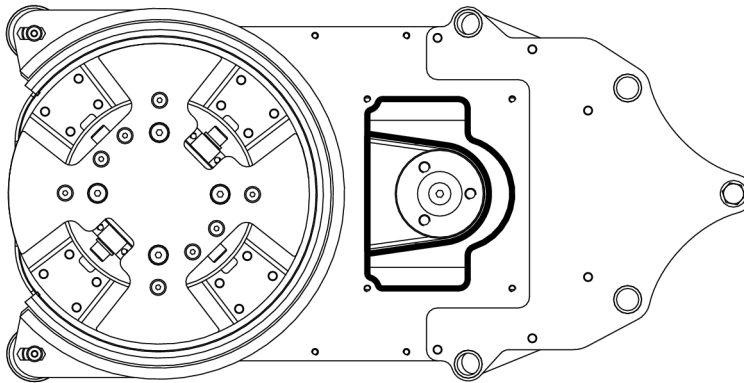

G000515

*Figure 5-1. Inspection cover for belt*

3. Check if the belt and the space in which it sits is dusty or otherwise dirty. If the belt is subjected to too much dust, there is a risk that it will slip and wear out faster. Clean the belt and the space around it thoroughly by vacuum cleaning away any dust and other dirt.
4. Rotate the grinding holder slowly and at the same time check the belt's condition by inspecting it visually. Continue until you have inspected the entire belt.

5. Check the belt tension by turning the belt according to Figure 5-2, page 32. It should be possible to turn the belt approximately 1/10 of a turn by hand.

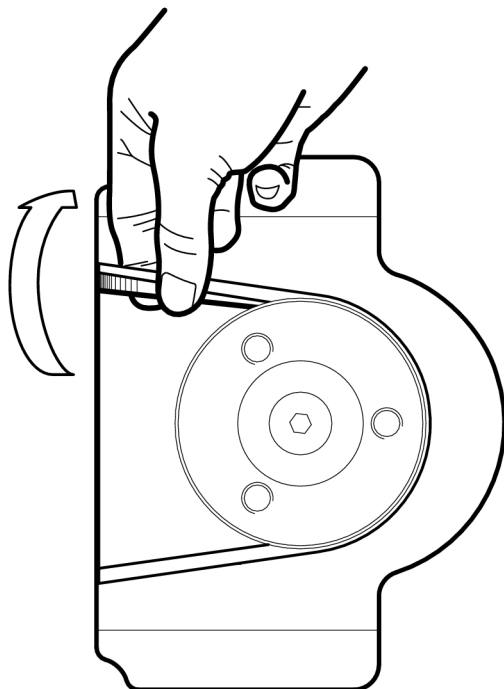

G000514

Figure 5-2. Checking belt tension



**Note!**

The belt is a consumable part. Its lifetime can vary depending on the operating conditions.

## 5.5 Every month (or 100 hours)

- Check that all screws and joints are tightened and correctly attached.
- Check that the grinding cover is whole and undamaged.
- Scrape and vacuum-clean the parts shielded by the grinding cover.
- Test run and listen for any dissonance from the bearings.



## 5.6 Repairs

Any repairs that may be required must be carried out by a HTC Service Centre, which has trained service personnel and uses HTC original parts and accessories. Contact your retailer if your machine requires servicing. For contact information, see Contact Information at the start of the manual.

## 5.7 Spare parts

To ensure rapid delivery of spare parts, always specify the model, the machine's serial number and the spare part number when ordering. Information on the model and serial number can be found on the machine's name plate.

Information on spare part numbers can be found in the machine's spare parts list which is available to read or print out from the accompanying digital media or HTC's website:

[www.htc-floorsystems.com](http://www.htc-floorsystems.com)

Only original tools and original spare parts from HTC may be used. Otherwise neither the CE marking nor the warranty will be valid.

## 6 Faultfinding

### 6.1 General Information

This chapter describes all the faults that may occur and how to deal with them. If the fault cannot be dealt with, or if there are other faults, contact your nearest retailer. See Contact Information at the front of the manual.

### 6.2 The machine will not start

- Check the machine is connected to the mains supply.
- Check the correct voltage is being supplied to the machine.
- Check if the emergency stop switch on the control panel is pressed. Reset the switch by turning it 45°.
- Check to see whether the converter is in a fault condition and, if so, remedy this as follows:
  - Reset the electronics by turning the Grinding knob to “Reset”. If this does not help, reset the frequency converter according to the instructions in chapter Electronic error codes, page 36.
  - Check the error code in the converter, see the error code table in chapter Electronic error codes, page 36.
- Check the fuses in the control cabinet.
- Check that the connector is correctly connected on the underneath of the control cabinet.

### 6.3 The machine vibrates or wears the tool unevenly

- Check the grinding head is correctly adjusted, see Adjustment of grinding head, page 24.
- Check the grinding holder. Recondition or replace the grinding holder as required.
- Check the tool holder. Recondition or replace the tool holder as required.

### 6.4 The machine is grinding at an angle

- Check the grinding head is correctly adjusted, see Adjustment of grinding head, page 24.
- Recondition the grinding holder. See under The machine vibrates or wears the tool unevenly, page 34.

## 6.5 The machine stops immediately after starting

- The overload indicator lights up because the speed of the grinding discs is too high. Reduce the speed and try again.
- Check the error code in the display on the frequency converter, see Electronic error codes, page [36](#).

## 6.6 The fuses trip frequently

- The load is too high on the distribution box to which the machine is connected. Use a different socket or reduce the speed of the machine.
- Check the tools. Ensure that the correct tools are used, that they are in working order and that they are correctly fitted.

## 6.7 The machine cannot cope

- Heavy load. Press the handle down slightly so that the grinding head eases slightly away from the surface being ground.
- Sticky coating on the surface being ground. Run half of the machine on the surface to be processed and half on the clean surface. This removes any residue from the tools.
- Check the tools. Ensure that the correct tools are used, that they are in working order and that they are correctly fitted.
- Voltage drop. Check that the cable area meets HTC's recommendations. You will find the recommended cable area under Technical data, page [40](#).



### Tip!

Check the minimum recommended cable area before using an extension cord. You will find the recommended cable area under Technical data, page [40](#).

## 7 Electronic error codes

### 7.1 General Information

A common fault on grinders is that the motor is overloaded.

In the event of an error, the error code is shown in the display. The most common error codes that may occur on the frequency converter in the control cabinet are listed below. In the event of other errors, contact the HTC Service Centre.

### 7.2 Schneider Electric ATV12

Error code	Cause	Action
OCF	Excess current	The machine is running too fast or with too great a load. Lower the speed, lower the load by changing the position of the weights and check your tools. Check mechanical inertia, spin the grinding discs.
OHF	Overheating	Open the control cabinet and ventilate. Check the filter and the cooling fans in the cabinet. Let the frequency converter cool down before restarting.
InF / EEf	Internal error	Contact HTC Service Centre
SCF	Short circuit or earth fault involving the motor	Check the motor's cables and connections.
tnF	Auto-tuning fault	Check the motor's cables and connections.
OLF	Overload	See OCF. Let the frequency converter cool down before restarting.
OSF	Excess voltage	Mains voltage too high or disturbance in the mains supply. Check the supply voltage, change socket.
USF	Under-voltage	The connection cable is too long, poor connection or too many consumers connected to the mains. Change socket, use shorter cables and lower the speed.
PHF	Mains supply phase break	Incorrect power supply to the frequency converter. Check the fuses in the mains supply and the connection cable.
OPF	Motor phase break	Check the motor's cables and connections.

#### 7.2.1 Resetting the frequency converter

1. Switch off the machine by turning the Power knob to "O".
2. Wait until the display goes out.
3. Reset the emergency stop switch.

4. Start the machine by turning the Power knob to "I".



**Tip!**

The machine will not start if the Grinding knob is in the "FWD" position when switching on the power.

**7.2.2 Checking the last error code**

For the buttons and knobs described here, see Figure 7-1, page 37

1. Press Enter. rEF is shown in the display.
2. Turn the knob counter-clockwise, until non is shown in the display.
3. Press Enter. rEF is shown in the display.
4. Turn the knob counter-clockwise, until nA1 is shown in the display.
5. Press Enter. LIS1 is shown in the display.
6. Turn the knob counter-clockwise, until dP1 is shown in the display.
7. Press Enter. The last error code is shown in the display.

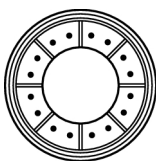

Figure 7-1. Enter button and knob - Schneider

**7.3 Schneider Electric ATV312**

Error code	Cause	Action
OCF	Excess current	The machine is running too fast or with too great a load. Lower the speed, lower the load by changing the position of the weights and check your tools. Check mechanical inertia, spin the grinding discs.
OHF	Overheating	Open the control cabinet and ventilate. Check the filter and the cooling fans in the cabinet. Let the frequency converter cool down before restarting.
IFx/EEF	Internal error	Contact HTC Service Centre
SCF	Short circuit or earth fault involving the motor	Check the motor's cables and connections.
tnF	Auto-tuning fault	Check the motor's cables and connections.

Error code	Cause	Action
OLF	Overload	See OCF. Let the frequency converter cool down before restarting.
OSF	Excess voltage	Mains voltage too high or disturbance in the mains supply. Check the supply voltage, change socket.
USF	Under-voltage	The connection cable is too long, poor connection or too many consumers connected to the mains. Change socket, use shorter cables and lower the speed.
PHF	Mains supply phase break	Incorrect power supply to the frequency converter. Check the fuses in the mains supply and the connection cable.
OPF	Motor phase break	Check the motor's cables and connections.

### 7.3.1 Resetting the frequency converter

1. Switch off the machine by turning the Power knob to "O".
2. Wait until the display goes out.
3. Reset the emergency stop switch.
4. Start the machine by turning the Power knob to "I".



#### Tip!

The machine will not start if the Grinding knob is in the "FWD" position when switching on the power.

### 7.3.2 Checking the last error code

For the buttons and knobs described here, see Figure 7-2, page [39](#)

1. Press Enter. rEF is shown in the display.
2. Turn the knob counter-clockwise, until SUP is shown in the display.
3. Press Enter. FrH is shown in the display.
4. Turn the knob counter-clockwise, until LFt is shown in the display.
5. Press Enter. The last error code is shown in the display.

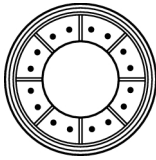

*Figure 7-2. Enter button and knob - Schneider*

## 8 Technical data

The table below shows the machine's technical data.

Machine type		HTC 270 EG 1 x 230 V, 50 Hz EU		HTC 270 EG 1 x 230 V, 60 Hz US	HTC 270 EG 3 x 460 V, 60 Hz US
Part number	Article no.	501054	Item no.	113256	113325
Total machine weight	kg	103	lbs	227	227
Weight, grinding head	kg	55	lbs	121	121
Chassis weight	kg	48	lbs	106	106
Grinding pressure	kg	36	lbs	79	79
Grinding diameter	etc.	270	in	10.6	10.6
Grinding discs	etc.	1 x 270	in	1 x 10.6	1 x 10.6
Motor	kW	2.2	hp	2.9	2.9
Voltage	W	1 x 230	W	1 x 230	3 x 460
Current	A	13	A	13	5
Recommended minimum cable area	mm <sup>2</sup>	2.5	in <sup>2</sup>	0.004	0.004
Frequency	Hz	50	Hz	60	60
Rotational speed, grinding discs	rpm	455-1210	rpm	455-1210	455-1210
Storage temperature	°C	-25...+70	°F	-13...+158	-13...+158
Working temperature	°C	-10...+50	°F	14...+122	14...+122
Humidity	%	5-95	%	5-95	5-95
Sound power level, according to ISO 3741, measured using class 1 instruments as sound level meters.	dB(A)	100	dB(A)	100	100
Vibrations, grinding/polishing	m/s <sup>2</sup>	3.92	m/s <sup>2</sup>	3.92	3.92
Permitted daily exposure, grinding/polishing	h	13	h	13	13
Vibrations, Floor preparation (T-Rex)	m/s <sup>2</sup>	3.75	m/s <sup>2</sup>	3.75	3.75
Permitted daily exposure, Floor preparation (T-Rex)	h	14.2	h	14.2	14.2



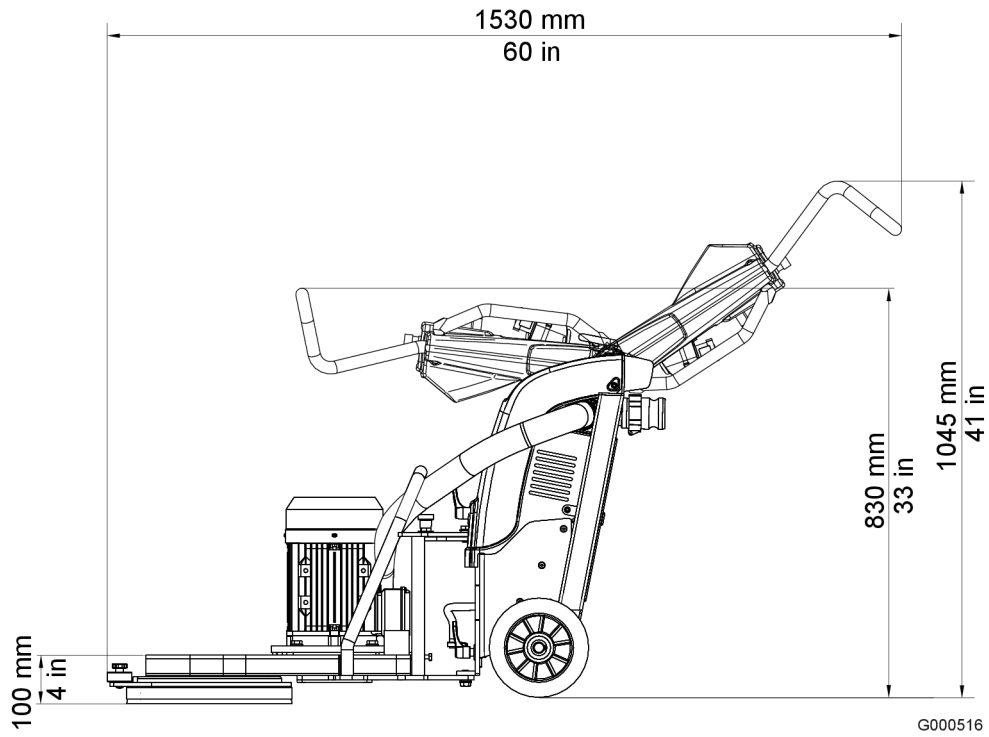
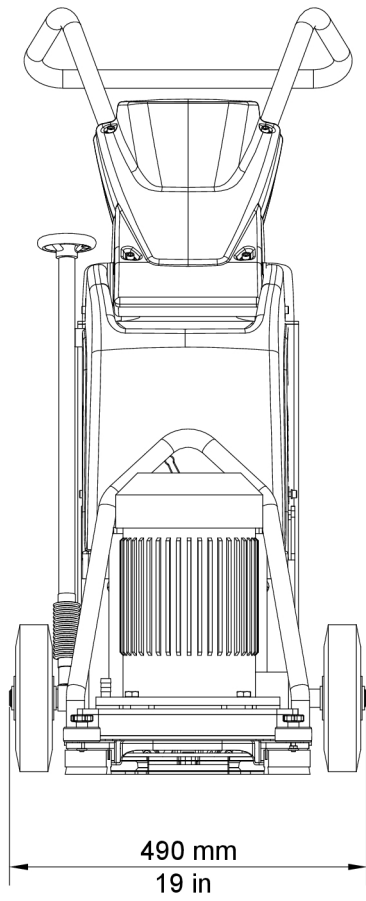
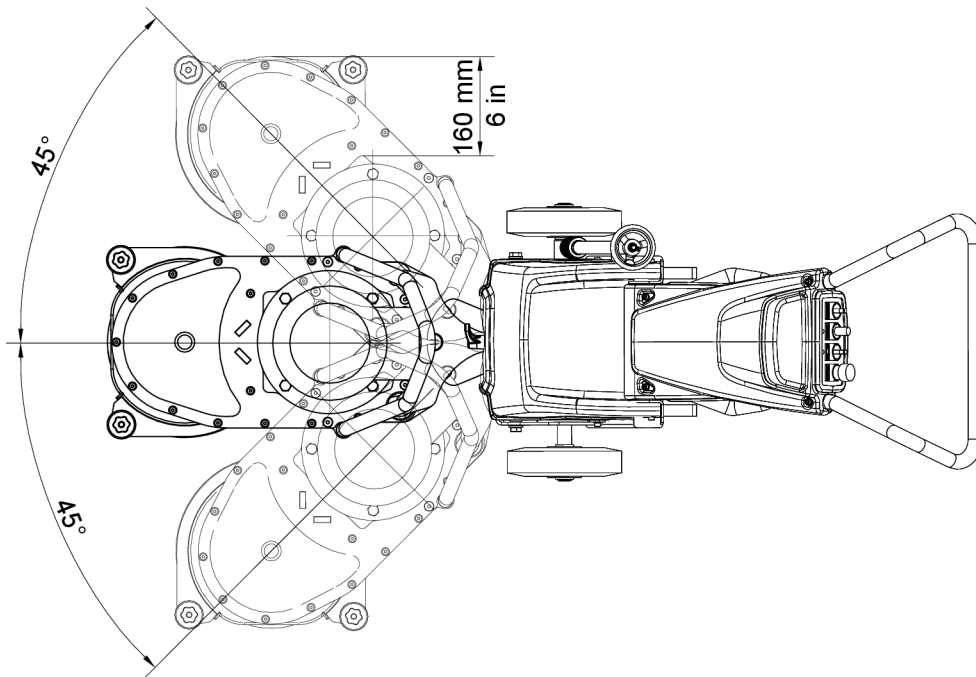

Figure 8-1. Height and length of the machine in millimetres



G000517

*Figure 8-2. Width of the machine in millimetres*



G000518

Figure 8-3. Working angles for the grinding head

## 9 Environment

HTC's products are constructed mainly of recyclable metal and plastic. The main materials used are listed below.

<b>Chassis</b>	
Frame	Metal, powder-coated
Wheels	Rubber
Fixed parts	Metal
Hose connections	Metal, aluminium
Hoses	Plastic, PUR and PVC
Covers	Plastic, ABS
Support blocks	Plastic, ABS

<b>Grinding head</b>	
Cover	Metal, powder-coated
External plate and steel components	Metal, powder-coated
Belts	Rubber and polyamide
Support wheels	Plastic, PA
Other plastic parts	Plastic, POM
Other components	Untreated steel

<b>Electrical system</b>	
Cables	Copper conductors with neoprene and PVC coating
Motor	Metal, cast iron, aluminium and copper
Control cabinet enclosure	Metal, powder-coated and stainless steel

Plastic components can be recycled by sorting as hard plastics. Electronics can be deposited as electronic waste. The machine or machine components can also be returned to HTC Sweden AB. For recycling and scrapping of components, see the applicable national regulations for each country.

## **10 Warranty and CE marking**

### **10.1 Warranty**

This warranty only covers manufacturing defects. HTC bears no responsibility for damage that arises or occurs during transportation, unpacking or use. In no instance and under no circumstances shall the manufacturer be held responsible for damage and defects caused by incorrect use, corrosion or use outside the prescribed specifications. The manufacturer is not responsible for indirect damage or costs under any circumstances. For complete information on the manufacturer's warranty period, see HTC's current warranty terms.

Local distributors may have special warranty terms specified in their terms of sale, delivery and warranty. If there is any uncertainty regarding warranty terms, please contact your retailer.

### **10.2 CE marking**

CE marking of a product guarantees its free movement within the EU area in accordance with EU regulations. CE marking also guarantees that the product fulfils various directives (the EMC Directive and other possible requirements in so-called directives for new procedures in accordance with these regulations). This machine carries the CE mark in accordance with the Low Voltage Directive (LVD), the Machinery Directive and the EMC Directive. The EMC Directive states that electronic equipment must not disturb its surroundings with electromagnetic interference and also that it must be immune to electromagnetic interference in its surroundings.

This machine is classified for use in environments such as heavy industry, light industry and, for certain machine types, even in homes. See the Manufacturer's Declaration of Conformity, which shows that the machine is harmonised with the EMC Directive.